

CMS Connections with Integrated CBB Keypad

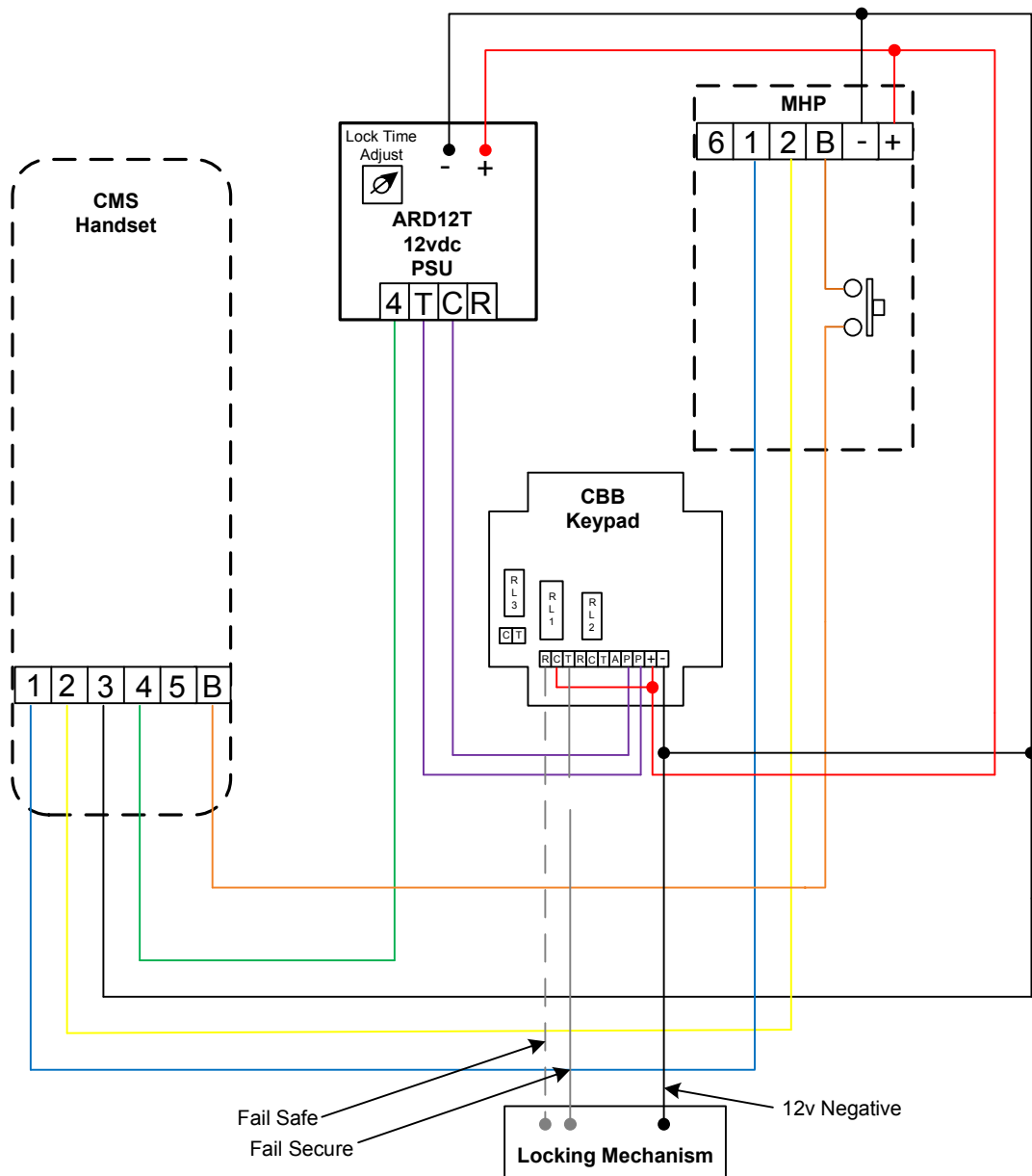

Notes:

- This wiring schedule allows full control of the locking mechanism via the keypad.
- The keypad must be wired and configured as CBB PRO100 instructions
- The timer on the ARD12T must be set to zero, lock is adjusted using the keypad programming *1 command.
- A “request to exit button” can also be connected to “P-P”.