



CMS/MHP/ARD12T

Call frequency

- Two frequency approximately. 900Hz and 1300Hz.

WIRING DIAGRAM

Wiring with an electric strike 12 VDC and a relay to control a light

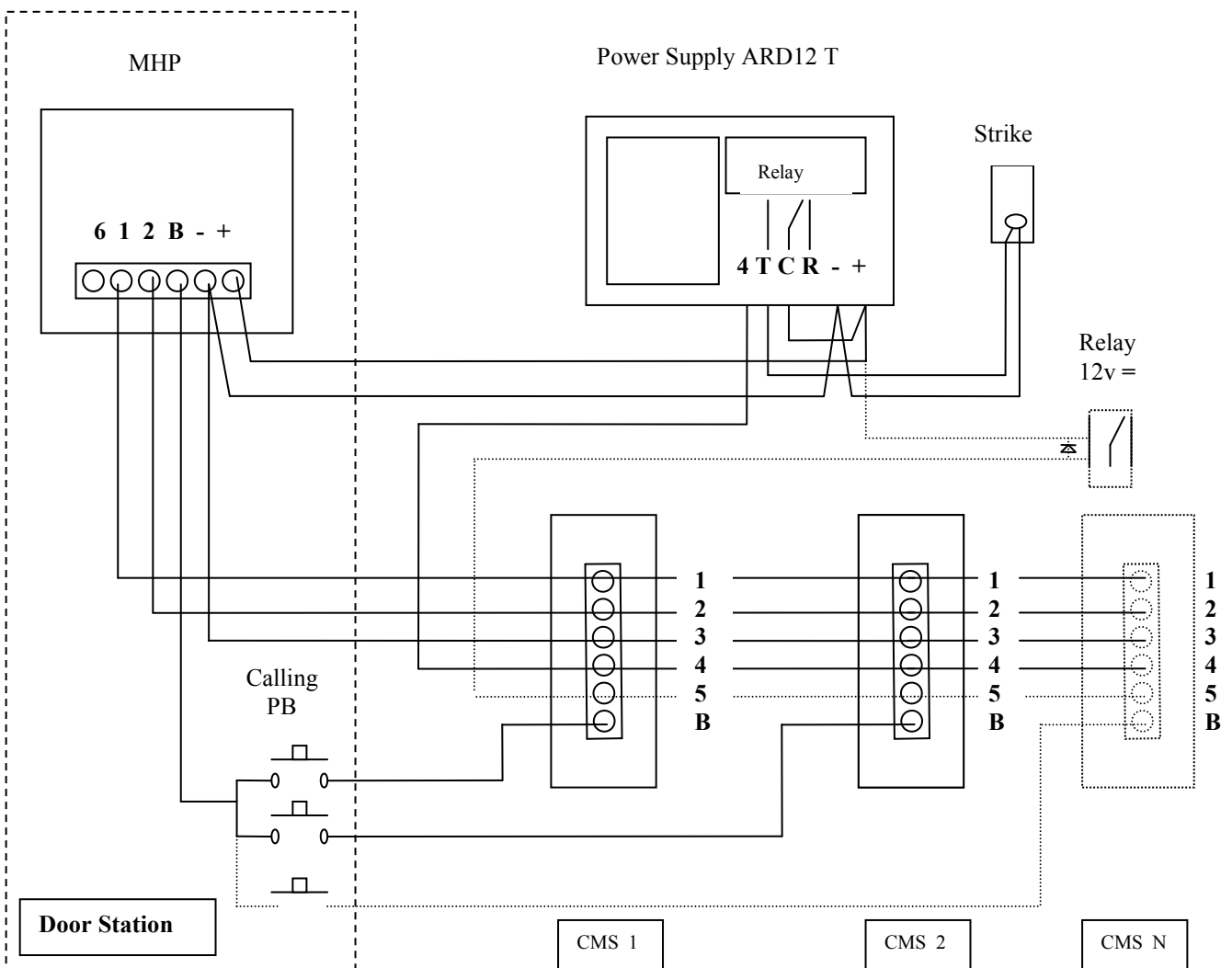

	Distance between speaker and Handset		Between Power Supply and Speaker	
Cable AWG	22	20	22	20
Distance in meter	300	500	20	30

MOUNTING INSTRUCTIONS

-The microphone speaker can be mounted on the intercom front plate panel (from 4 mounting holes).

Or

-The microphone speaker can be fixed by using a U bracket which will be mounted on the back cover of the intercom panel

-The handset is mounted on the wall with two screws which comes with the handset.

-Remove the screws from the top cover of the handset.

-Revolved the top cover to open the handset.

-Mount the handset base on the wall.

-Connect the cable on the handset according to the wiring diagram.

-Make sure that the wire is clipped back properly before closing back the top cover.

-Put back the screw.